

MOISTURE ENTRAPMENT IN BUILDINGS WITH EIFS AND STUCCO FACADES IN THE STATE OF FLORIDA

BY KATHRYN M. BARKER AND MICHAEL G. KNETTEL

(This article is reprinted with permission from the Proceedings of Thermosense XXI, Volume 3700, pp. 463-470, International Society for Optical Engineering (SPIE), Bellingham, WA., April 1999.)

ABSTRACT

In the state of Florida, explosive population increases have promoted monumental efforts by the building industry to keep up with the demand for public facilities such as schools, hospitals, and multiple story housing (condominiums). The onslaught has brought with it various industry-related problems, one of which is interior building permeation more commonly known as moisture intrusion.

Exterior Insulation and Finish Systems (EIFS) and stucco veneer buildings are cost-efficient and follow the guidelines for ever shortening construction timeframes. However, shortened construction time is also part of the reason for failures of these systems. This, combined with the underlying structural building components and their differential thermal expansion (known as the

Coefficient of Expansion), loan themselves to the problematic conditions observed in numerous projects throughout the Southeast.

Hurricanes, severe thunderstorms, heavy humidity, and other forms of atmospheric conditions found in the Southeast (and more so in Florida) accelerate the aging process of the two aforementioned systems. These, combined with the factors described above have brought the investigation of the two systems to the forefront for countless building owners.

This paper presents thermographic examples of case studies performed by the authors on Exterior Insulation and Finish Systems (EIFS) and stucco veneer buildings within the state of Florida and is presented to raise awareness of damage that can occur when EIFS or stucco systems fail.

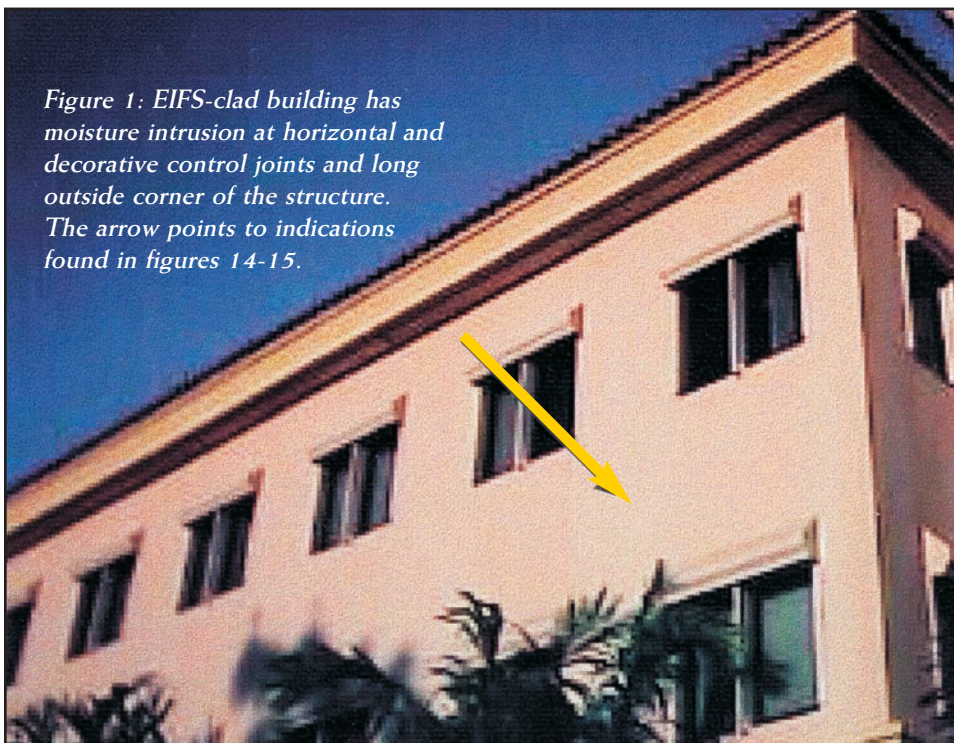

Figure 1: EIFS-clad building has moisture intrusion at horizontal and decorative control joints and long outside corner of the structure. The arrow points to indications found in figures 14-15.

Introduction

Thermographic investigation is the beginning process for many building owners experiencing water intrusion problems. Commonly, the owner has dealt previously with the intrusion and is now faced with where to start the repair or replacement process. In this arena, thermography is valuable because with good technique it can efficiently locate water intrusion sources.

A thermographic investigation is often undertaken to provide an unbiased, third-party view, and results in a fact-finding mission. In this situation, the owner is requiring validation/evidence as to the source of the water intrusion so that he or she can implement proper repair and/or seek reimbursement for his or her losses. Such are the cases that prompted this paper. Due to an explosive population increase in Florida, rapid construction has ensued in order to deal with the burden. This response has produced many less-than-acceptable public facilities and there are actually billions of dollars in repairs at stake in the foreseeable future.

For these reasons, there are presently many similar investigations being conducted utilizing thermographic study.

Thermographic images of four of the buildings being investigated are provided herein. The facilities are located in various counties throughout the state. The buildings have been experiencing external veneer failures which resulted in severe water intrusion problems.

Stucco and EIFS are two popular external veneers utilized in Florida and other parts of the U.S. Inasmuch as all external veneers suffer similar problems to EIFS and stucco, most veneers take 12-15 years to demonstrate problems, whereas problems with EIFS can show up in 3-5 years.

Stucco systems basically use a mixture of cement, sand, and lime. This plaster-like mixture is applied in either an open-frame method or a direct-application system. EIFS typically consists of insulation board made of polystyrene foam secured to an external wall and coated with a water-resistant base coat followed by a finish coat.

Water Intrusion Thermograms Demonstrating Failing Cement-based Stucco

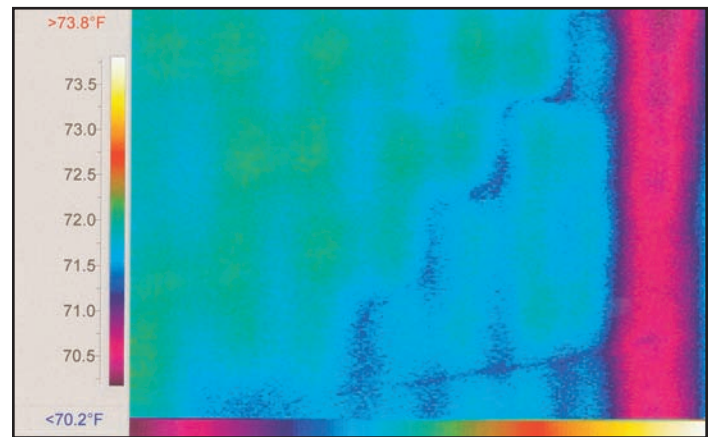
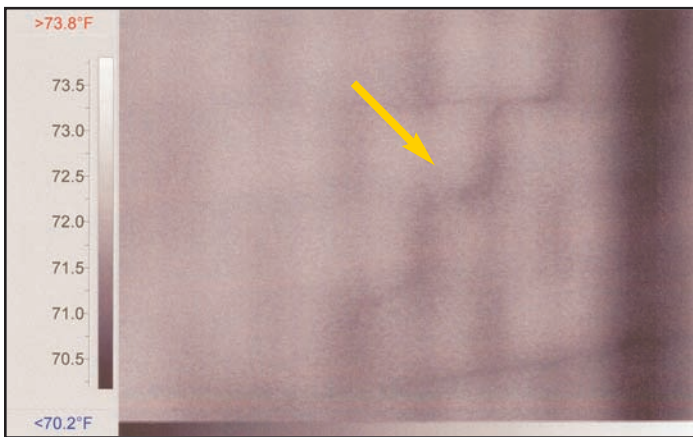

Figures 2 (left) and 3 (right) demonstrate stair-step cracking typical of common cement-based stucco failure found in Florida. The stair-step cracking is found in corner conditions such as shown in the thermograms of Figures 2 and 3 and is due to lateral movement in the concrete frame caused by thermal expansion. This causes cracks in the stucco, opening a gap for the transmission of water to the building interior. The failure mechanism in this case was the lack of proper bond separation between the concrete block and poured concrete frame. At the time of construction, there was a failure to provide a control joint in this location.

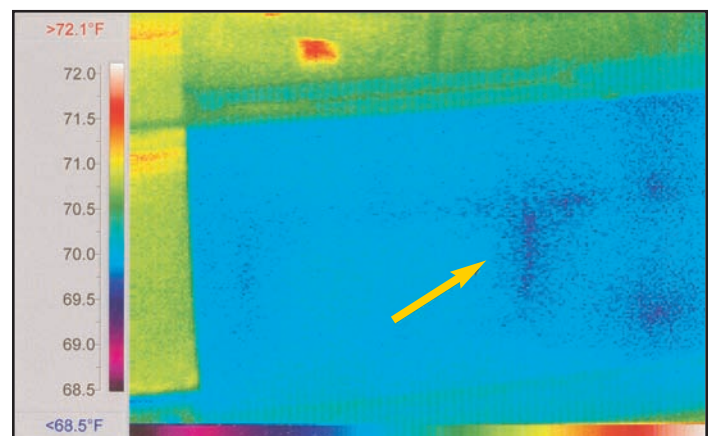

Figures 4 (left) and 5 (right) are thermograms showing water intrusion and are the interior wall of Figures 2 and 3. Water intrusion was extensive at this facility. The anticipated repair procedures and cost will exceed \$1.2 million.

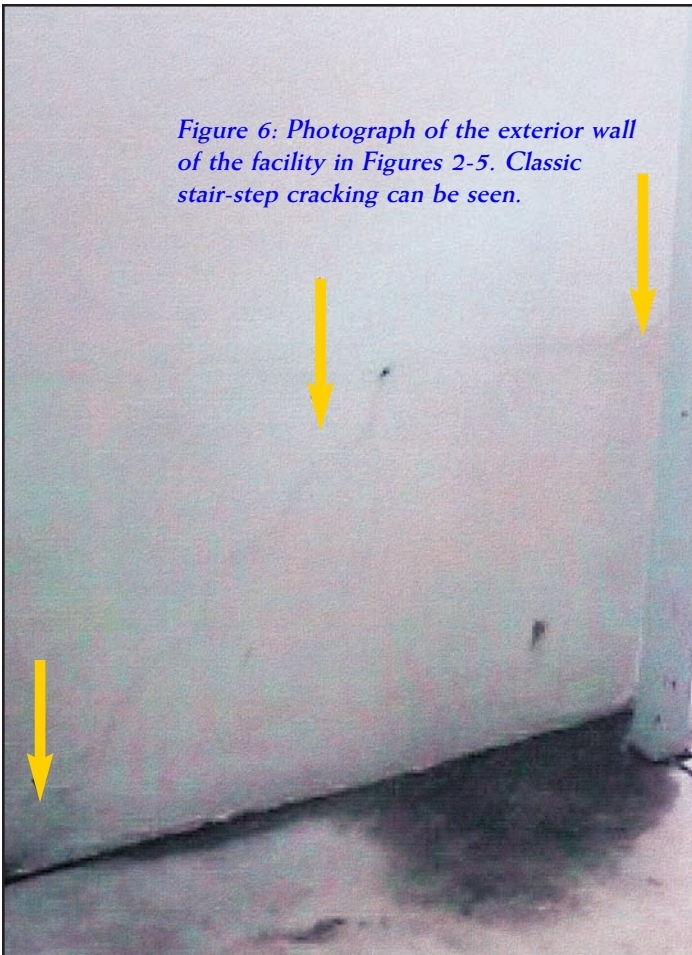

Figure 6: Photograph of the exterior wall of the facility in Figures 2-5. Classic stair-step cracking can be seen.



RCI, Inc.
800-828-1902
www.rci-online.org

Stucco and EIFS Descriptions

Traditional stucco is a cementitious exterior plaster coating available in a wide range of colors and textures. Its characteristics are similar to concrete in that stucco is porous, it shrinks and cracks; however, it has high impact resistance. Applied like plaster, stucco is a mixture of sand, cement, lime, and water. Two coats are applied to masonry substrate and three coats to metal lath. The finish coat may be tinted by adding coloring matter to the mix, or the outside surface may be painted with a suitable material. Stucco systems shed water because stucco has a drainage plane. This drainage capability is provided by building paper installed shingle-fashion over the exterior sheathing and under the metal lath. The paper breathes, allowing water vapor to escape. It is a proven system that works in all climates.

EIFS (non-drainable systems) consists of a polymer-modified or polymer-based synthetic coating applied as a reinforced base coat and finish coat over rigid thermal insulation board. The last two steps lend the appearance of traditional cement and lime stucco.

Conventional EIFS is designed to act as a moisture barrier and does not incorporate a drainage cavity for penetrated moisture. Without a drainage cavity, sealed joints and perimeter flashing are critical elements in the cladding's success or failure. In regions where extended periods of rain or damp cold are common, EIFS has little to no tolerance for moisture. Any water seeping behind the watertight exterior can become trapped, thus leading to damage that can go unnoticed until extensive deterioration has occurred to the structure.

The European community's success with EIFS applied over masonry substrates fueled the United States into a phenomenal growth of the application. However, the U.S. building industry applied EIFS over non-masonry substrates such as metal studs and sheathing. Unfortunately, EIFS applied over non-masonry substrates did not prove as successful as the European application method.

A call to industry quality standards was initiated when there was a pronounced increase of water intrusion problems and damage to building structures nationwide as a direct result of

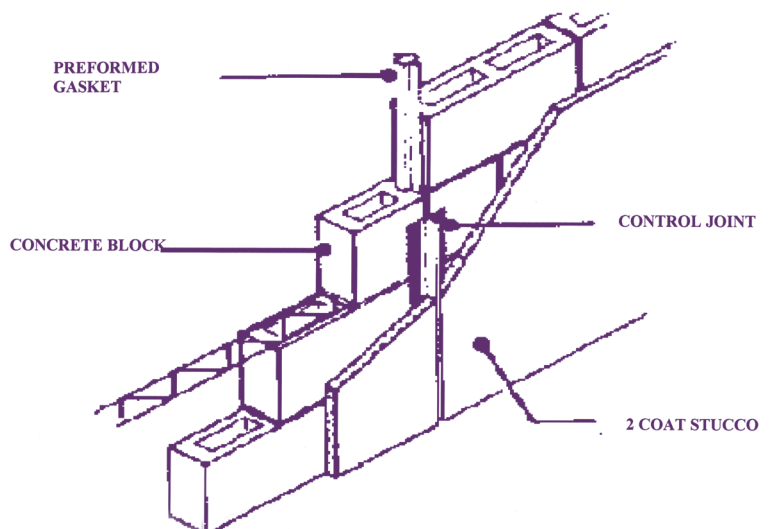
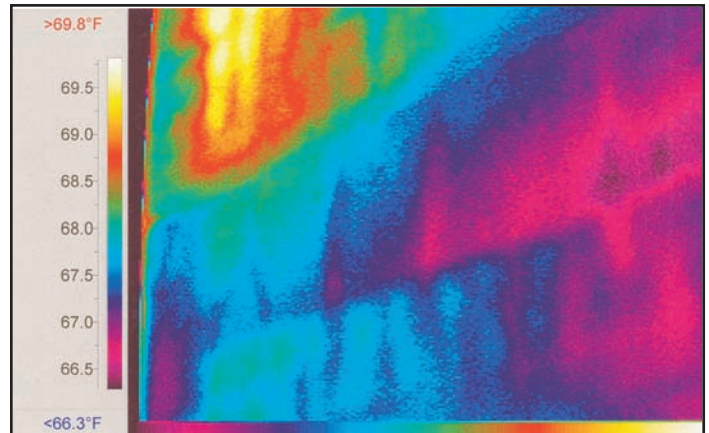
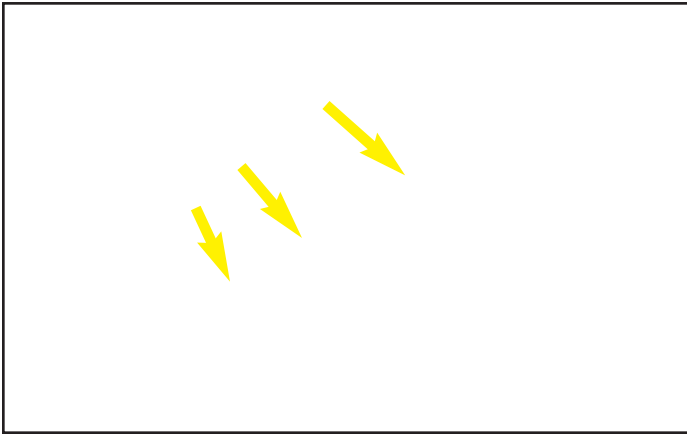
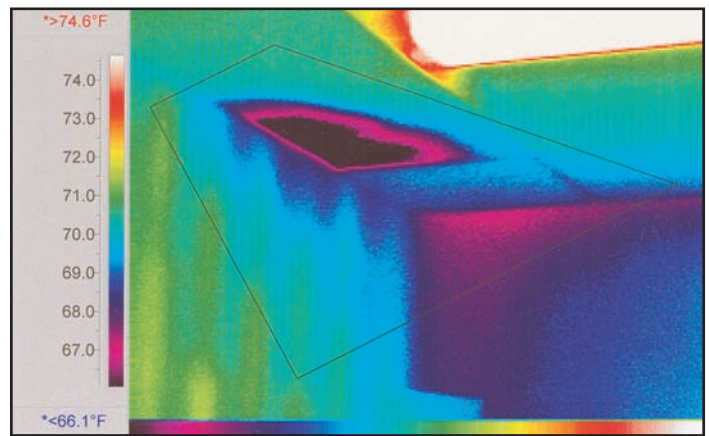
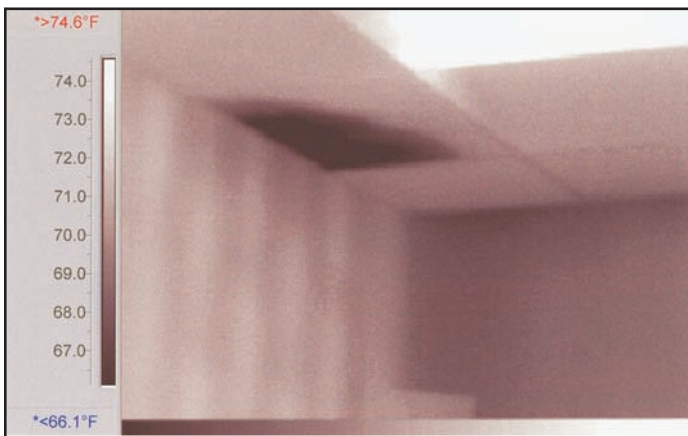

Figure 7: Rough drawing of the wall mechanism demonstrated in figures 8-11.

Water Intrusion Thermograms Demonstrating Failing Cement-based Stucco



Figures 8 (left) and 9 (right) are thermograms demonstrating disbonding of cementitious-based stucco from concrete block. The failure mechanism was a combination of lack of wire lath and improperly mixed stucco.



Figures 10 (left) and 11 (right) are thermograms of the interior wall of Figures 8 and 9.

non-drainable EIFS installation. Poor installation practices and lack of attention to detail were the apparent reasons.

The awareness was driven by field experience with system failures, maintenance, and repairs. Our new understanding of EIFS behavior has forced the development of improved details and application procedures. In response, industry leaders introduced drainable EIFS. Drainable EIFS is similar to non-drainable EIFS in composition with the added advantage of a drainage mechanism in place similar in effect to that of traditional stucco systems. The new drainable system reduces the likelihood of trapped moisture and so reduces damage inside the wall cavity. However effective the new system may be, heightened awareness to details and installation procedures has had a positive effect on the EIFS installation outcome as well.

Besides being remarkably energy efficient, EIFS has great design flexibility and "curb appeal." Also, when compared to standard brick or wood construction, both of the aforementioned EIFS categories can reduce air infiltration by as much as 55%, stabilize interior environments, and reduce energy consumption. Due to the inherent mechanisms of their materials and structural assembly, EIFS materials increase the "R value" of a building significantly. Most EIFS assemblies use insulation board

with an R value of R-4 to R-5.6 per inch as the innermost layer in the wall system. When combined with standard wall cavity insulation, the extra layer can boost wall insulation from R-11 to R-16.

Inspection Key Points

Prior to any thermographic investigation, a thorough history of the building should be assembled. This should include original plans if available, construction materials used, and any information pertaining to the inspection being performed. A solid understanding of the structural components of the building is essential so that any thermographic indications found can be readily explained. A good overall visual inspection should also be completed prior to initiating thermographic scanning. Again, this is done to explain any indications found. Establish a dialog with the building's owner, caretaker, or custodial service. These persons generally know the history of the building and any outstanding problems.

When traditional stucco is used as the external veneer, certain visual indications are generally found. These are predecessors to or are indications of a failing system. Look for efflorescence; peeling paint; fine, eggshell-type cracking (craz-

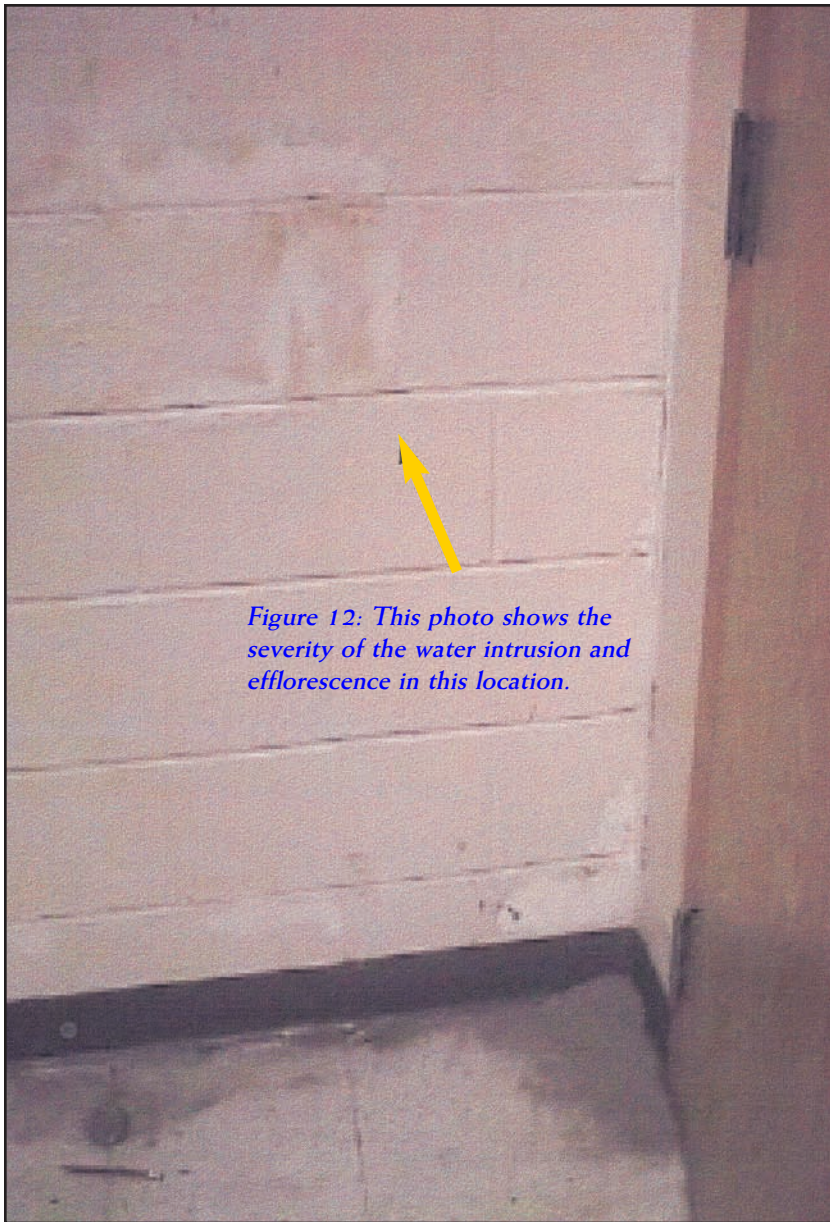

Figure 12: This photo shows the severity of the water intrusion and efflorescence in this location.

ing); disbonding; delaminations; separation of caulking from its applied surface; and significant stucco cracking at building transitions.

Also, look at the direction of the cracking. Significant multiple cracks in the same direction can imply a lack of normal expansion capabilities of the stucco. One of the underlying causes of this is dissimilar material and their varying rates of thermal expansion (coefficient of expansion).

The thermal expansion of stucco can be managed with control joints placed in a 4:1 ratio. Look for stucco thickness in excess of 3/4 inch, thinning stucco at corners of window ledges or door openings, and any penetrations or openings through the surface of the membrane. Also look for areas in the stucco surface where the wire lath is found to broadcast itself to the visual surface.

EIFS indications are remarkably similar to traditional stucco systems. Pay special attention to areas of detail as these are the first to fail in a poorly-constructed system. Look for anomalies at window and door flashings. Check the caulking and gaps around decorative trim. Look for water stains on interior walls or at the base trim. Also, look at the building's transitions. These locations are generally the first to fail.

To focus only on EIFS or stucco without reviewing the wall system as an assembly is to assume that each product in the wall operates independently. Certainly, there is symbiosis between products such as sheathing, EIFS or stucco, windows, flashings, and sealants. All of these must be properly installed for the wall system to function efficiently.

Conclusion

The scenarios that produced the water permeation problems in the buildings of this report could have been prevented had the veneer application

Water Intrusion Thermograms Demonstrating Failing Cement-based Stucco

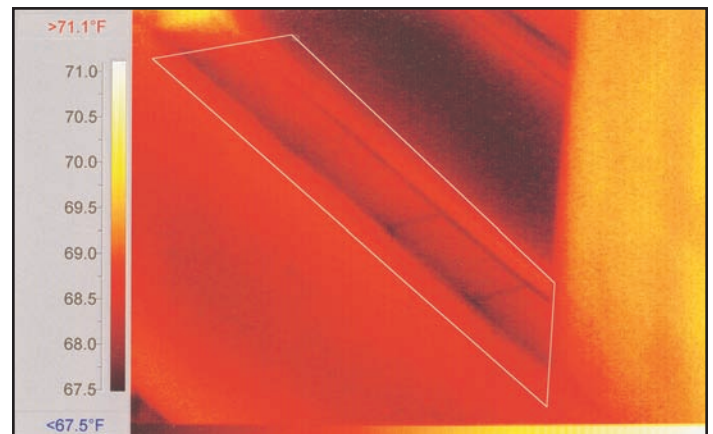
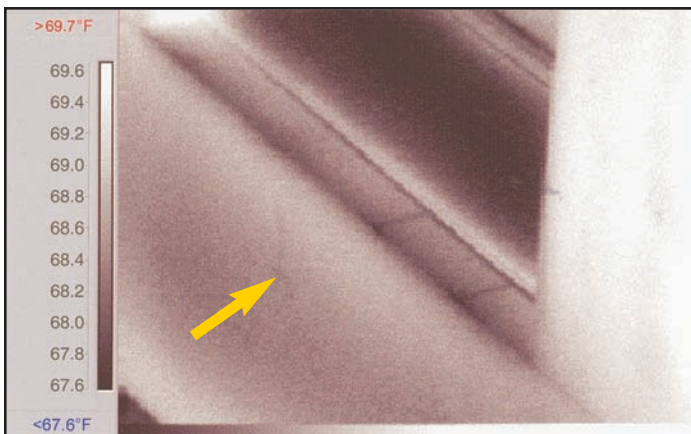

Figures 13 (left) and 14 (right) are thermograms of water intrusion at a window ledge. Moisture intrusion was caused by lack of caulking and caulking bond failure.

EIFS Over Structural Sheathing

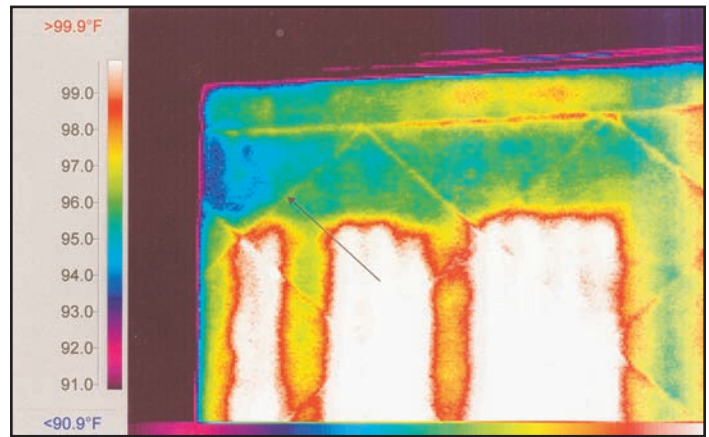
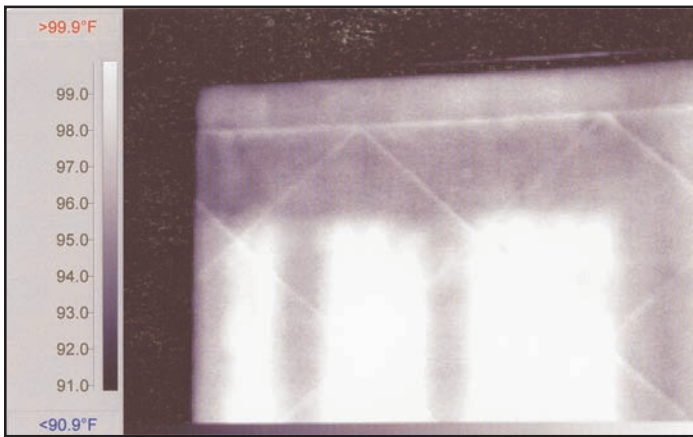
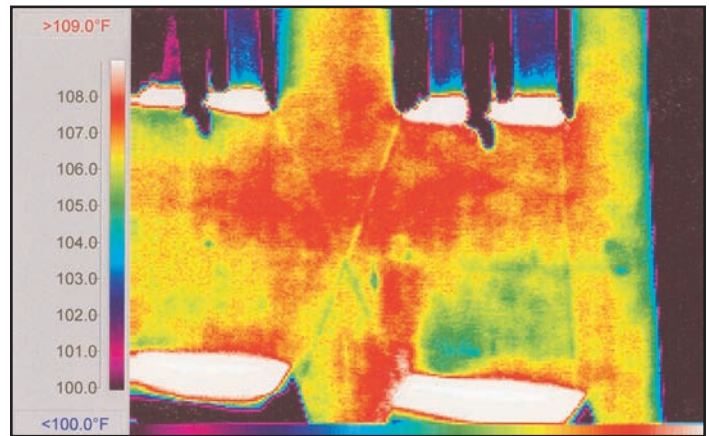
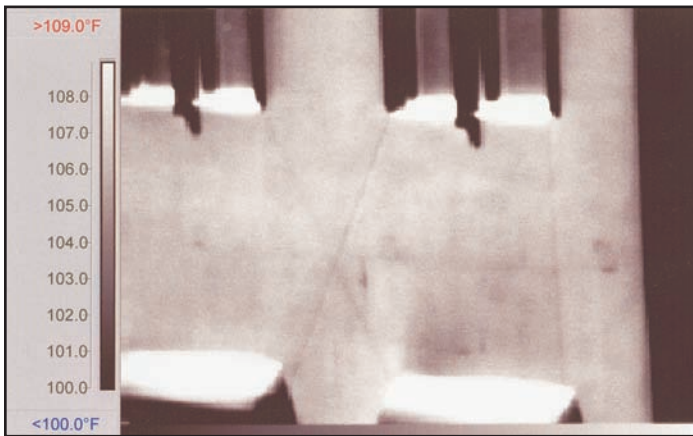

Figures 15-18 (above) demonstrate moisture intrusion at horizontal and decorative control joints and along the outside corner of an EIFS-clad structure in Central Florida. The failure mechanism was a combination of poor installation technique and lack of attention to detail. Please note the water intrusion indications in Figure 16 (blue and green on top right graphic). These are typical of non-drainable EIFS veneer.

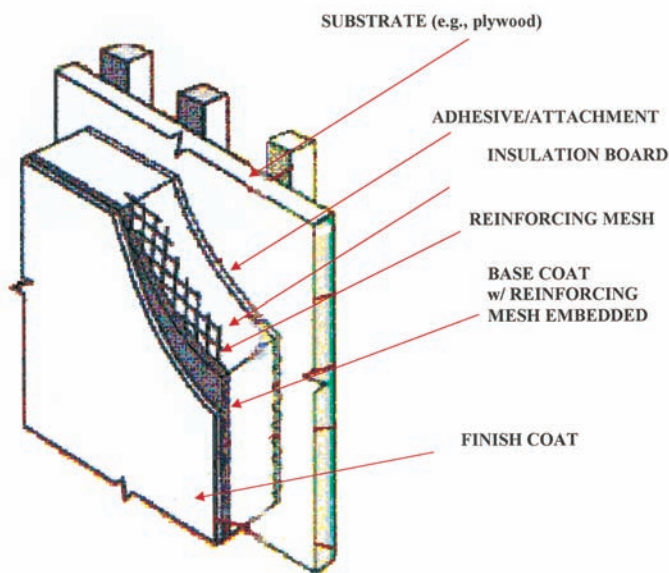

Figure 19 is a rough drawing of the wall mechanism demonstrated herein.

crews paid more attention to the installation details involved. As simple as that sounds, quality control means everything.

Unlike automobiles or computers, there is not a maximum life expectancy to be factored in to predict when a building or facility is to be torn down. The life expectancy for today's automobile (even though it seems to be as soon as the loan is paid off) is ten years. Computers are one to two years—three if you're lucky.

There is no maximum life expectancy for buildings and it is not acceptable for owners to invest millions of dollars into a building, only to be told five years down the road that there are severe structural problems due to water permeation and that it will cost millions to repair the damage. No matter how efficient the veneer in every other way, water damage is no tradeoff.

The four buildings presented in this paper will be participating in continuing thermographic studies for years to come. The results of the studies will be presented at a future date; however, according to the owners of the buildings, there will be several million dollars in repairs required in the immediate future. ■

Definitions

Efflorescence. White fleecy deposit on the face of plastered walls, caused by salts in the sand or backing. Also referred to as "whiskering" or "salt-petering."

Coefficient of Thermal Expansion. The change in length, per unit of length, for a change of one degree of temperature.

Lath. An expanded metal layer substrate base to receive plaster.

Stucco. Applied like plaster, stucco is a mixture of sand, cement, lime, and water. Two coats of the cementitious material are applied to concrete masonry unit substrate and three coats to open frame metal lath assembly. The finish coat may be tinted by adding coloring matter to the mix, or the outside surface may be painted with a suitable material.

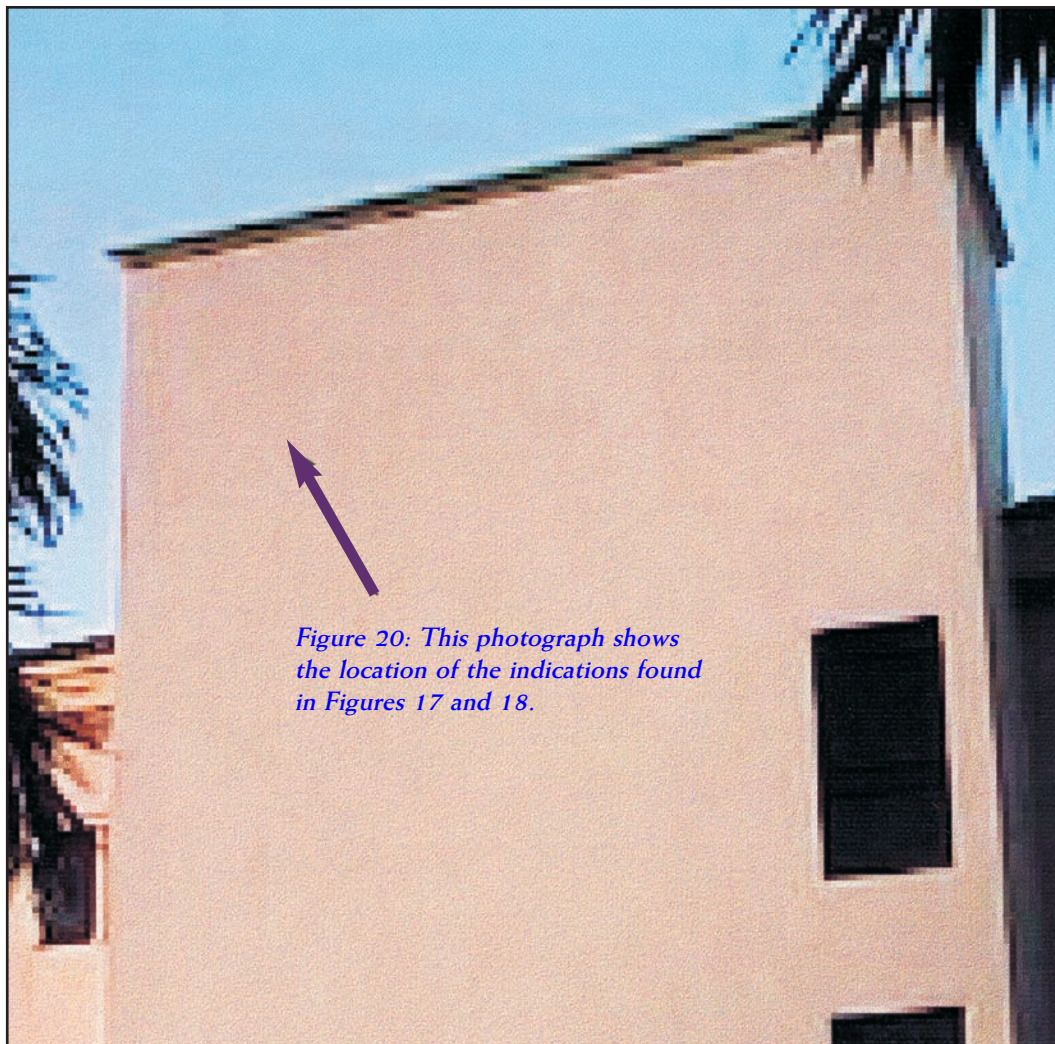

Figure 20: This photograph shows the location of the indications found in Figures 17 and 18.

References

1. Merritt, *Building Design and Construction Handbook*, pp. 3-43. McGraw Hill, New York, 1996
2. Evans, *EIFS News Archives*, pp. 1. www.eifs-facts.com 1998.
3. Beall, Christine, *Thermal and Moisture Protection Manual for Architects, Engineers and Contractors*, pp. 351-390. McGraw Hill, New York, 1998.
4. Horsley, *Means Graphic Construction Standards*. 1st Edition, pp. 148. Means Publication, Kingston, NY, 1992
5. American Institute of Steel Construction, *Manual of Steel Construction*, pp. 397. 1995

ABOUT THE AUTHOR



KATHRYN M. BARKER

Kathryn M. Barker has been active in the field of nondestructive testing (NDT) since 1977. She holds Level IIs in six test methods and an ASNT Level III in Thermal Infrared. Her NDT career began with the Trans Alaska Pipeline Project and continued on various gas transmission pipelines throughout the U.A. In 1986 she accepted a position in the NDT Laboratory with EG&G of Florida at Kennedy Space Center, where she spent 8 years with the technical staff. Following this, she accepted a position as an Engineering Support Specialist which led to the position as Supervisor of the laboratory. Presently she is the owner of

American Infrared Testing and Consulting in St. Petersburg, FL.

Michael G. Knettel Sr. is an Infrared Level II Thermographer and Certified State of Florida General Contractor. He conducts building

analysis for moisture intrusion problems and building condition surveys. Knettel holds a BS degree in Civil/Structural Engineering and a masters in Architecture. Knettel is Past President of an infrared company and a loss control firm. He is presently serving as an OSHA instructor for continuing education for contractors and conducting site safety audits for construction projects.



MICHAEL G. KNETTEL SR.